

<b>T.I. No.:</b> 2020 - 16 <b>Updated:</b> -	<b>Topic:</b> Check mixer sealing ring (V-ring)
---	---

<b>Date:</b> 18.05.2020
<b>Affected machines:</b> SCSoul
<b>From serial number:</b> 20 12 xxx xxx /20 19 xxx xxx
<b>As of date:</b> 16.03.2020 - 08.05.2020

Priority	
x	High
	Medium
	Low

Need for action	
x	As soon as possible
	On next visit to the machine
	FYI only

## INCORRECTLY INSTALLED MIXER V-RING FROM SUPPLIER

The V-ring (3) on the mixer motor retaining ring was mounted incorrectly from the supplier. It is recommended to check each machine.

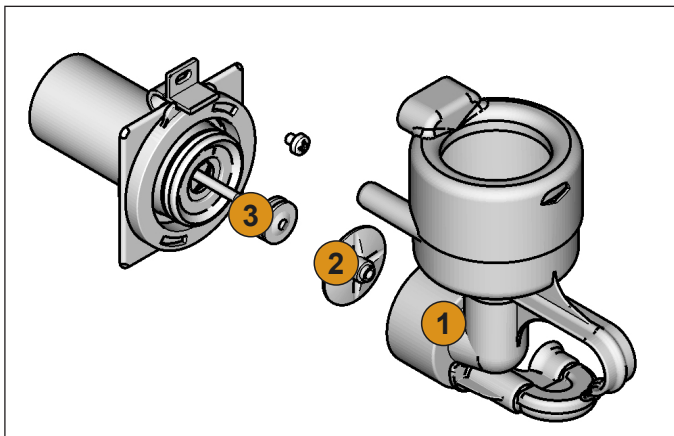

Mixer and mixer motor

- ▶ Remove the mixing bowl (1) to the front.
- ▶ Remove the Impeller mixer (2) towards the front.



Incorrectly mounted V-ring

### A MASCHINE NOT USED

- ▶ Visual inspection of the V-ring.
- ▶ Realign the V-Ring.
- ☑ V-ring is unkinked and well mounted.

### B MACHINE WAS ALREADY OPERATING

- ▶ Check the V-ring and replace if needed.
- ▶ Inspect the motor for defects.
- ☑ Mixer shaft does not rotate > Motor defective.
- ▶ Replace the mixer and the impeller as one unit.



(3) V-ring mixer 078995



Mixer motor 33.2872.5000

**NOTE**  
The necessary spare parts can be ordered free of charge from Sales Export Switzerland until 1 July 2020 by quoting the serial number.