

# **Cafitesse 120**

## **Next Generation**

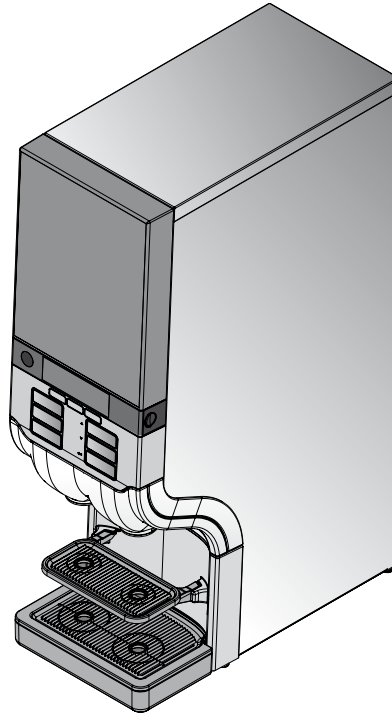

Operator manual

Copyright 2010 © Sara Lee International Foodservice, Netherlands

The English version is the original version of the operator manual. Other languages are translations of the original operator manual.

# TABLE OF CONTENTS

<b>1 Introduction .....</b>	<b>4</b>	<b>5 Cleaning the dispenser .....</b>	<b>22</b>
About the dispenser .....	4	Cleaning procedures .....	22
About this operator manual .....	4	Clean & Flush .....	22
<b>2 Safety instructions .....</b>	<b>5</b>	Flush .....	26
General .....	5	Manual daily cleaning .....	27
Installation .....	6	<b>6 Display messages and trouble</b>	
Transport, storage and operation ..	7	<b>shooting .....</b>	<b>28</b>
Servicing the dispenser .....	7	<b>7 Technical specification .....</b>	<b>31</b>
Food safety instructions (HACCP) ..	8	<b>8 Options .....</b>	<b>33</b>
<b>3 Components of the dispenser..</b>	<b>11</b>	Software options .....	33
Front of the dispenser .....	11	Hardware accessories .....	33
Rear of the dispenser .....	11	<b>9 Index .....</b>	<b>35</b>
Icons on the display .....	12		
<b>4 Operating the dispenser .....</b>	<b>13</b>		
Place cups and pots correctly .....	13		
Drink delivery .....	13		
Portioned or continuous drink			
delivery .....	14		
Drink delivery with preselections ..	15		
Inserting and removing product			
packs .....	17		
Switching on the dispenser .....	19		
Setting date and time .....	20		
Switching off the dispenser .....	21		
Locking/unlocking the dispenser ..	21		
		<b>Cleaning procedure</b>	

# 1 INTRODUCTION

## About the dispenser

The Cafitesse 120 is a dispenser for the delivery of coffee, espresso, tea, cocoa containing drinks, and only hot water in commercial sectors.

The dispenser functions using special disposable product packs. These patented „Bag-in-Box“ (BIB) product packs contain high quality liquid drink concentrate for drink production. The dispenser can hold one product pack.

The drinks can be dispensed into cups and pots of various sizes.

Optionally you can request your Cafitesse system supplier to equip your dispenser

- with a height extension foot for the delivery into larger pots and air pots (see „Options“)
- with a one line cold water valve for the delivery of cold water (see „Options“)
- with a two line cold water valve for the delivery of cold drinks and cold water (see „Options“)

- with a special mixing unit for the delivery of cocoa containing drinks (see „Options“)
- with a door lock to prevent unauthorized access to the dispenser.

Please note, that the options listed above may not apply in each country.

## About this operator manual

This operator manual describes the main applications and functions of the dispenser. Before starting to use the dispenser, please read this operator manual to ensure that you have understood the operation of the machine and the safety instructions.

You will find the following symbols throughout this operator manual, please pay attention to them:



**Note:**

Additional information which may be helpful during the dispenser operation.



**Caution:**

Information to which you should pay careful attention in order to ensure food safety, to prevent personal injury or damage to the dispenser.



**Warning:**

**Dangers that can result in severe personal injury, death and/or severe damage to the dispenser.**



**Danger:**

**DANGERS THAT WILL RESULT IN SEVERE PERSONAL INJURY OR DEATH.**

## 2 SAFETY INSTRUCTIONS

### General

Please read the instructions in this operator manual carefully before using, cleaning or moving the dispenser. Ensure that you and all other persons who operate, clean or move the dispenser are familiar with, and act according to, the safety and hygiene aspects of the dispenser.

You may only use the dispenser according to the instructions in this operator manual for the delivery of drinks. The manufacturer is not liable for any damage or injury resulting from improper use of the dispenser or from non-compliance with the procedures described in this operator manual.

- The installation, servicing, repair and programming of the machine may only be carried out by an authorised and appropriately trained service technician assigned by your Cafitesse system supplier.
- Only use original spare parts for the operation of the dispenser.
- The operation, filling and cleaning of the dispenser may only be carried out by authorised and trained personnel.

- The dispenser is not suitable for outdoor use.
- The dispenser must be installed where it can be supervised by trained personnel.



*Warning:*

**The liquids delivered by the dispenser are hot!**

**Avoid scalding!**

**Keep hands and other body parts away from the dispenser while drinks are being dispensed and during the rinsing program.**



*Warning:*

**Do not place cups, pots, or containers filled with hot liquids on top of the dispenser. There is the risk of being scalded, in case the cups/pots/containers fall down.**



*Warning:*

**Keep sufficient space around the dispenser to get away easily in case of hot liquid splashes.**



*Warning:*

**This dispenser is not intended for use by persons (including children) with limited physical, sensory and mental faculties, or persons with insufficient experience and/or knowledge of the dispenser.**

**This does not apply if they are supervised by a person responsible for their safety or have received instructions on how to use the dispenser. Children should be supervised to ensure that they do not play with the dispenser.**



*Warning:*

**Place the dispenser on a table or counter with a minimum height of 60 cm/24 in to avoid that young children can press a drink button.**



*Caution:*

**Check and empty the drip tray of the dispenser regularly to avoid the risk of being scalded and to avoid a wet floor (slip danger) when (hot) liquids spill out of the drip tray.**

## I 2 SAFETY INSTRUCTIONS

### Installation

The installation and programming of the dispenser may only be carried out by authorised and appropriately trained service technicians assigned by your Cafitesse system supplier.

The dispenser is designed for installation indoors on a stable surface such as a table or counter.

- When setting up the dispenser, ensure there is a clearance of approximately 5 cm / 2 in between the dispenser and the wall.
- Protect the dispenser against frost, rain and direct sunlight.
- Protect the dispenser against running water, splashes, spray or steam, heat and heavy dust.



**Warning:**

**The dispenser may not be cleaned using a water jet and is not suitable for installation on a surface where a water jet may be used in the vicinity (e.g. for cleaning purposes).**

- Ensure that there is sufficient space around the dispenser for ventilation.
- Keep the front and rear of the dispenser accessible for cleaning and servicing.
- Connect the dispenser to the drinking water supply in compliance with local regulations.



**Caution:**

Only hose sets as per EN 61770 may be used to connect the water supply.



**Caution:**

If you intend to use the dispenser to deliver cold drinks, please check the drinking water quality according to local regulations beforehand to ensure that you obtain cold drinks that pose no health risks.

- Connect the dispenser according to local regulations to a secured electric circuit.

If you connect the dispenser to a plug in the wall, then:

- Use a grounded safety socket in compliance with local regulations.
- Ensure that the electric circuit is protected by a residual current device.
- Ensure that the plug remains accessible after installation.



**Warning:**

**Never touch the power source or plug if your hands, the power cord or socket are wet.**

If you connect the dispenser to a permanently wired power source (without mains plug), then ensure that the electric circuit is equipped with a circuit breaker with a contact gap of minimum 3 mm / 0.12 in that controls all poles.

## Transport, storage and operation

Always store and transport the dispenser in the original packaging. Before storing or transporting the dispenser:

- Place the product packs in the refrigerator.
- Clean the dispenser.
- Contact your Cafitesse system supplier so that an authorised and trained service technician can drain the water from the boiler and protect the dispenser against frost damage.



**Warning:**

**The dispenser may not be subject to frost during operation, storage or transport.**

If you suspect there is frost damage following storage or transport, contact your Cafitesse system supplier to have the dispenser checked and a function test implemented.

## Servicing the dispenser

The servicing, repair and programming of the dispenser may only be carried out by authorised and appropriately trained service technicians assigned by your Cafitesse system supplier.



**Warning:**

**If the mains cable of the dispenser is damaged, switch the dispenser off and contact your Cafitesse system supplier to have the mains cable replaced.**

## I 2 SAFETY INSTRUCTIONS

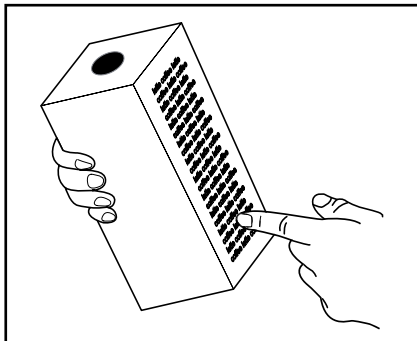

Fig. 1

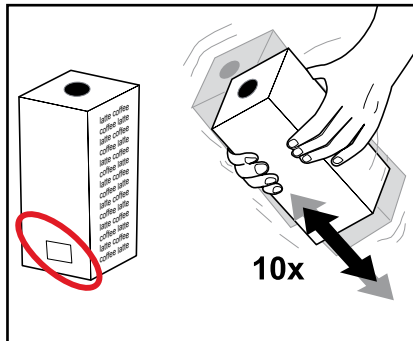

Fig. 2

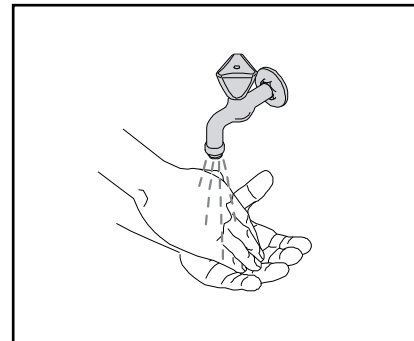

Fig. 3

### Food safety instructions (HACCP)

As the operator of the dispenser, you are responsible for its safe and hygienic operation. Please comply therefore with the following instructions in order to meet the food safety standards.

#### Storage of product packs

- Store the product packs according to the description on the packaging (fig. 1).
- Please note the „Best before“ date printed on the packaging (fig. 2).

- Always use the product packs according to the „first in -first out“ principle (product packs stored first must be used first).
- Do not use a product pack if the „Best before“ date has expired.

#### Handling the product packs

1. Wash your hands before touching a product pack (fig. 3).
2. Shake the product pack at least 10 times before inserting it in the dispenser (fig. 2).
3. Read the instructions on the rear of the pack.
4. Check the product pack for any damage. Never use a damaged product pack.
5. Check the „Best before“ date on the label of the product pack. Do not use a product pack if the „Best before“ date has expired.

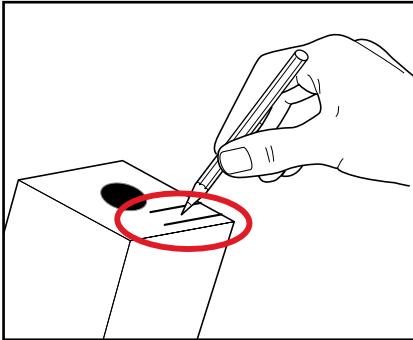

Fig. 4

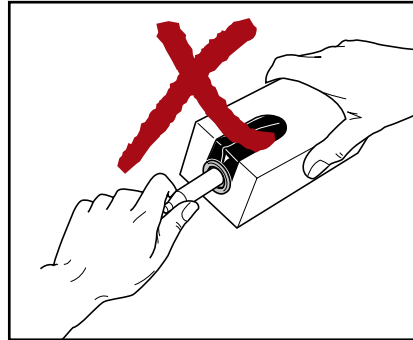

Fig. 5

6. Follow the instructions on the product pack. Write at least the expiry date on the product pack (fig. 4).

**Note:**

When the product pack is open, ensure that no liquid spills out onto clothing, the floor or other equipment.

**Caution:**

Do not touch the tip of the doser with your hands or the cleaning cloth. If the doser needs cleaning, rinse with clear water only (fig. 5).

If you do not use the dispenser for a longer period (e.g. during a company holiday), follow the instructions in the chapter „Switching the dispenser on/off“.

## I 2 SAFETY INSTRUCTIONS

### Cleaning the dispenser

Clean the dispenser regularly

1. Clean the surface around the dispenser.
2. Wash your hands before touching the dispenser or a product pack.
3. Clean the dispenser according to the instructions in the operator manual (see chapter „Cleaning the dispenser“).
4. During cleaning, check the „Best before“ and „Expiry“ dates on the product pack in the dispenser. If the „Best before“ or „Expiry“ date is expired, replace the product pack.
5. Schedule cleaning activities and record them.



**Caution:**

Clean all dispenser parts that come into contact with the product with a cleaning agent. Only use cleaning agents recommended by the food industry and your Cafitesse system supplier. For safe handling, dosing and use of cleaning agents, follow the instructions on the label of the cleaning agent.



**Danger:**

**DO NOT SPRAY OR SPLASH THE DISPENSER WITH WATER. DO NOT USE A WATER JET FOR CLEANING. NEVER IMMERSE THE DISPENSER IN WATER.**



**Danger:**

**NEVER TILT THE DISPENSER TO CLEAN BEHIND OR BELOW IT. AVOID SCALDING! THE BOILER CONTAINS VERY HOT WATER THAT CAN SPILL OUT IF YOU TILT OR MOVE THE DISPENSER.**

### Training

Train new staff regarding food safety instructions (HACCP).

- Inform new staff about schedules and cleaning procedures.
- Ensure that new staff reads the operator manual before operating the dispenser. Keep the operator manual close to the dispenser.

If there are any other questions, please contact your Cafitesse system supplier.

### 3 COMPONENTS OF THE DISPENSER

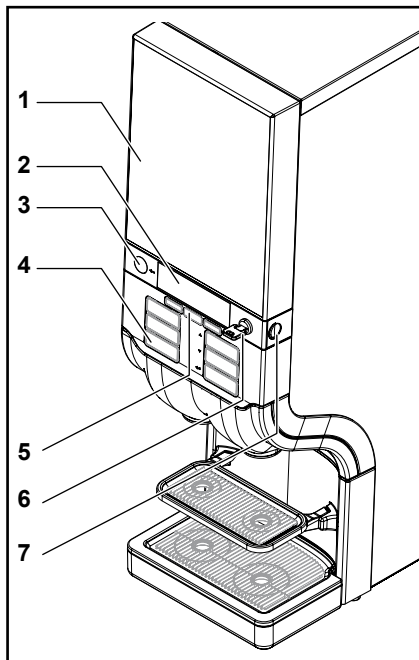

Fig. 6

#### Front of the dispenser:

- 1 - Dispenser door
- 2 - Display
- 3 - STOP-button
- 4 - Drink buttons
- 5 - Preselection buttons
- 6 - Door lock with key (option)

2010 - 11

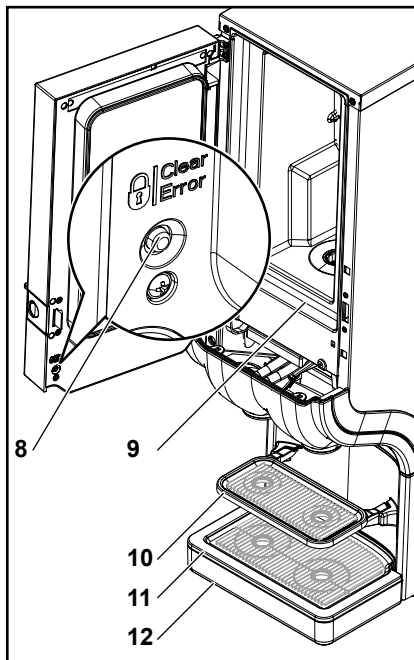

Fig. 7

- 7 - Door release button
- 8 - **LOCK**/Clear-Error switch
- 9 - Cooling compartment
- 10- Cup tray
- 11- Drip grid
- 12- Drip tray

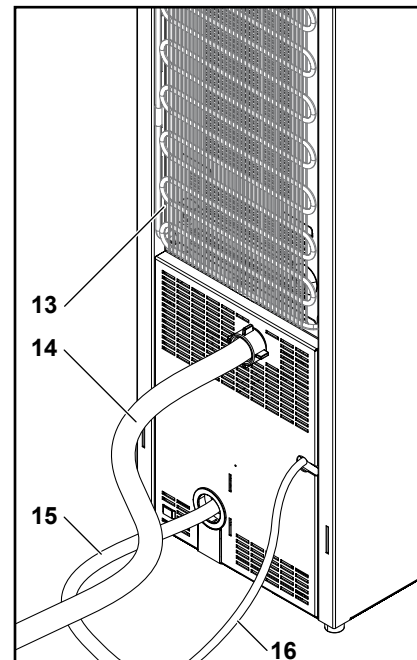

Fig. 8

#### Rear of the dispenser:

- 13- Condensate grid
- 14- Water supply hose
- 15- Power cord
- 16- Water supply hose for cold drinks/  
cold water (option)

### I 3 COMPONENTS OF THE DISPENSER

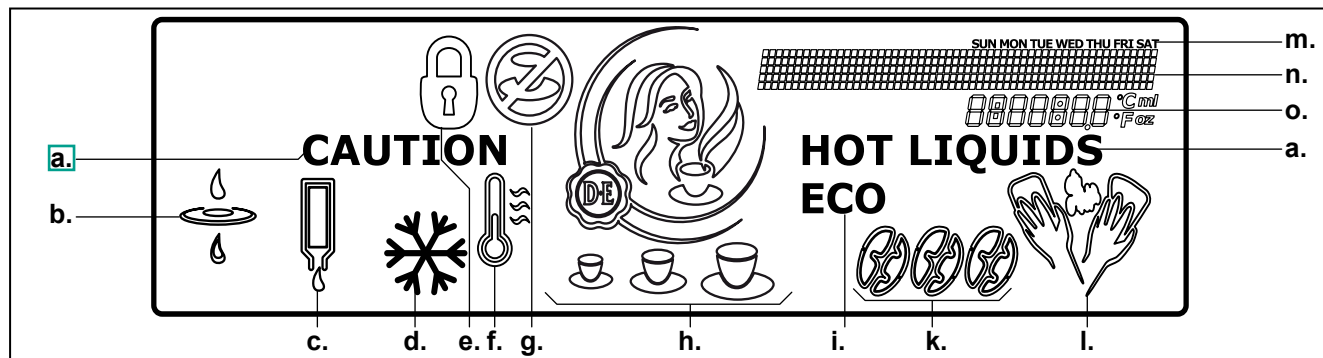

Fig. 9

#### Icons on the display:

##### a. CAUTION HOT LIQUIDS

the dispenser delivers hot water or hot drinks or  
the dispenser is flushed

##### b. FILTER

replace the water filter

##### c. PRODUCT PACK

insert a full product pack

##### d. ICED-preselection (option)

dispense a drink as cold drink

##### e. LOCK

the dispenser is locked and cannot dispense drinks

##### f. TEMPERATURE

the dispenser is heating up for the first time, and the water temperature in the boiler is too low (in combination with 'DELIVERY BLOCKED')

##### g. DELIVERY BLOCKED

the dispenser cannot deliver the selected drink

##### h. VOLUME-preselection

select a small, medium, or large drink

##### i. ECO

the energy saving mode is active

##### k. STRENGTH-preselection

select a mild, normal or strong drink

##### l. CLEANING

clean the dispenser

##### m. WEEKDAYS

##### n. MESSAGE-line

Messages are displayed to guide you through the cleaning steps, or in case of errors

##### o. INFO-field

display of cooling compartment temperature, time, etc.

## 4 OPERATING THE DISPENSER

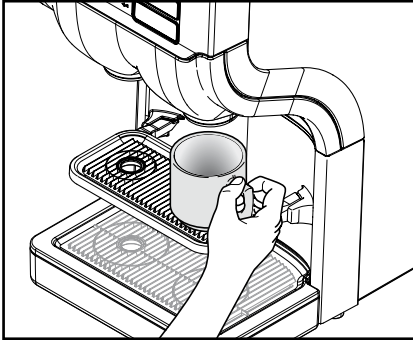

Fig. 10

### Place cups and pots correctly

The dispenser has two product outlets:

- Left: for coffee, tea, and cocoa containing drinks (option)
- Right: for hot water



#### Caution:

Place your cup or pot under the outlet below the drink button of your selection.

- Place your cup on the cup tray (fig. 10).
- Tilt the cup tray upwards to provide enough room for a pot (fig. 11).
- Place the pot on the drip tray (fig. 12).

A special dispenser foot may be required for larger pots.

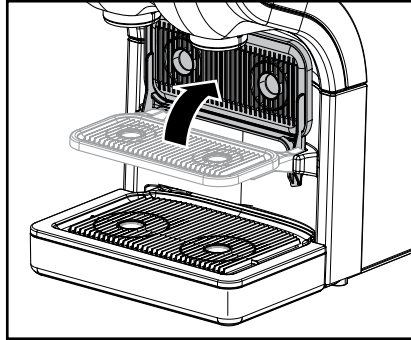

Fig. 11

### Drink delivery



#### Warning:

**The liquids dispensed by the dispenser are hot! Avoid scalding! Keep hands and other body parts away from the dispenser while drinks are being delivered. Never leave children unsupervised near the dispenser.**

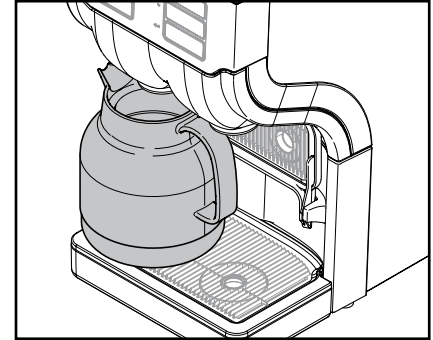

Fig. 12

### To deliver a drink:

1. Place your cup on the cup tray (fig. 10).
2. Press the drink button of your choice. The drink will be delivered via the corresponding outlet.
3. Press the STOP button if you want to interrupt or cancel the drink delivery.

## I 4 OPERATING THE DISPENSER

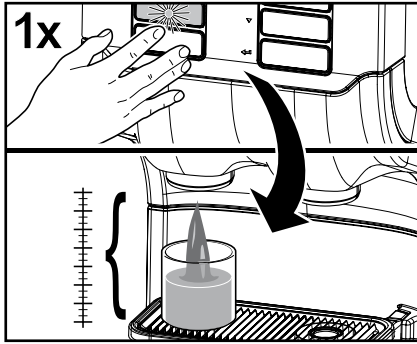

Fig. 13

### Portioned or continuous drink delivery

During installation, the service technician programs the dispenser to operate with one of the following delivery options.

- **Portioned delivery:**

The drink button only needs to be pressed once (fig. 13).

The dispenser stops automatically after one portion is delivered. (The respective portion volumes can be programmed by the service technician).



**Caution:**

Press the STOP button if the cup or pot is too small for the delivered drink volume and when there is the risk of scalding by spilling of hot liquids.

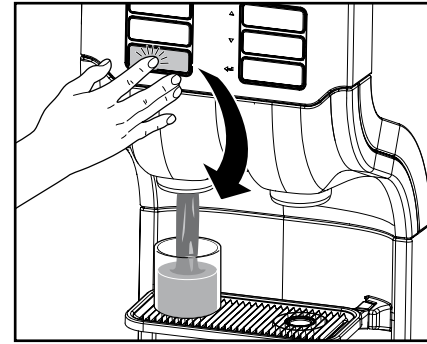

Fig. 14

- **Continuous delivery:**

The drink button must be kept pressed until the cup or pot is full (fig. 14). The dispenser stops when you release the drink button.



**Note:**

We recommend portioned delivery with fixed cup sizes in selfservice areas where customers may not be familiar with the operation of the dispenser.

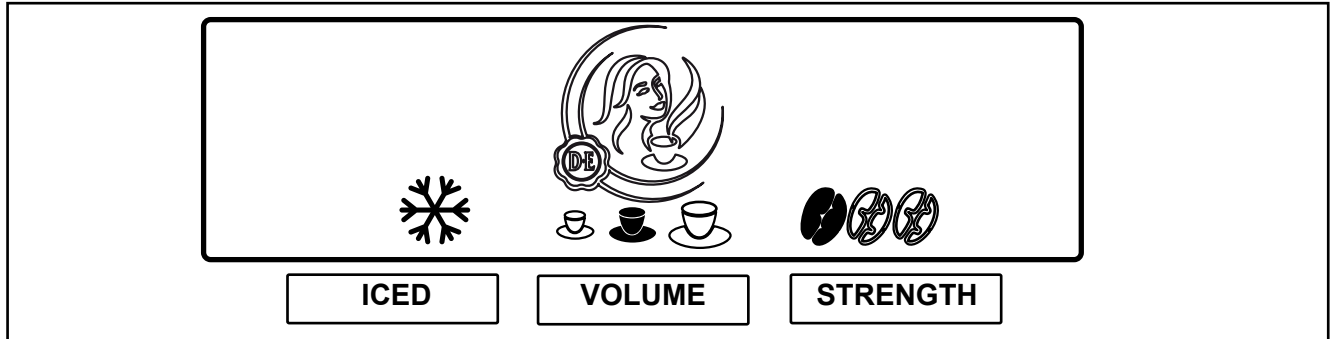

Fig. 15

### Drink delivery with preselections

Your dispenser supports preselection options. The service technician may have activated these preselection options during installation. When the preselection button is pressed, the following preselection options are displayed on the display (fig. 15):

- **ICED**-preselection (option)
- **VOLUME**-preselection (small - medium - large)
- **STRENGTH**-preselection (mild - normal - strong)

#### ICED-preselection (option)

1. Place your cup on the cup tray.
2. Press the preselection button «ICED» to activate this preselection. The icon for iced is displayed (fig. 15).
3. Press a drink button. The iced drink is delivered.
4. Press the STOP button to return to the default state.

#### VOLUME-preselection

1. Place your cup on the cup tray.
2. Press the preselection button «VOLUME» to activate this preselection. Three cup icons (small - medium - large) are displayed (fig. 15).
3. Press the preselection button until the required portion size is marked in black. The selection is cyclic.
4. Press a drink button. The drink is delivered with the selected portion size.
5. Press the STOP button to return to the default state.

## I 4 OPERATING THE DISPENSER

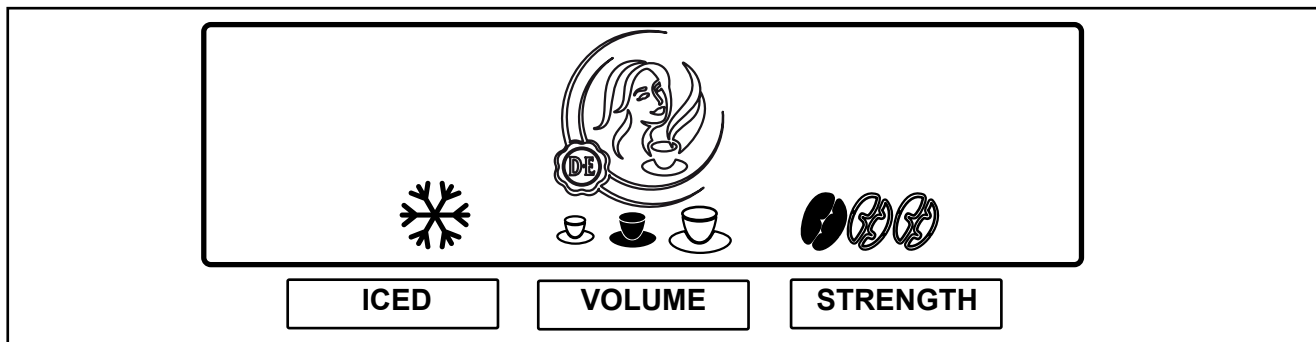

Fig. 16

### STRENGTH-preselection

1. Place your cup on the cup tray.
2. Press the preselection button «STRENGTH» to activate this preselection. Three bean icons are displayed (fig. 16).
3. Press the preselection button until the required drink strength is marked in black. Selection is cyclic. (1 bean = mild, 2 beans = normal, 3, beans = strong).
4. Press a drink button. The drink will be delivered with the selected strength.
5. Press the STOP button to return to the default state.



**Note:**

All preselection buttons can be combined with one another.



**Warning:**

**The liquids dispensed by the dispenser are hot! Avoid scalding! Keep hands and other body parts away from the dispenser.**



**Note:**

If you press a preselection button, but do not press the delivery button, the dispenser will return to the default state after a few seconds.

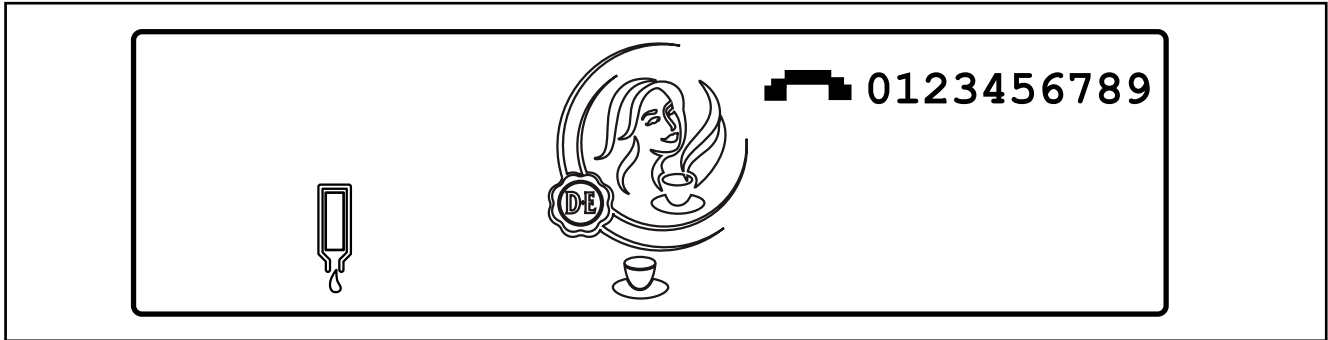

Fig. 17

## Inserting and removing product packs

### Empty product pack detection

If you select a drink and the corresponding product pack is empty, a drink will not be delivered. The icon for empty product pack will be shown on the display (fig. 17).

The delivery of hot or iced water is still possible.



**Note:**

The service technician can customise your dispenser to display a telephone number of your choice in the message line.

The following text will scroll in the message line:

**PRODUCT EMPTY ☒ 123456789**

Call the operator when necessary.

## I 4 OPERATING THE DISPENSER

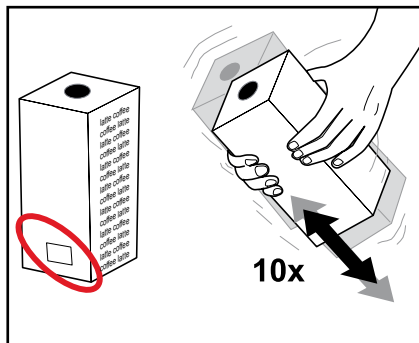

Fig. 18

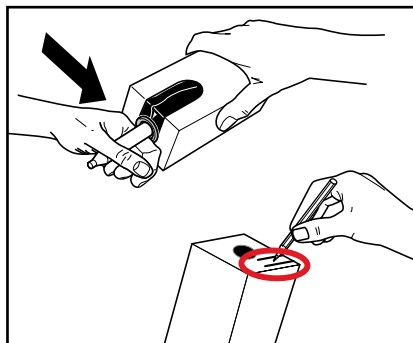

Fig. 19

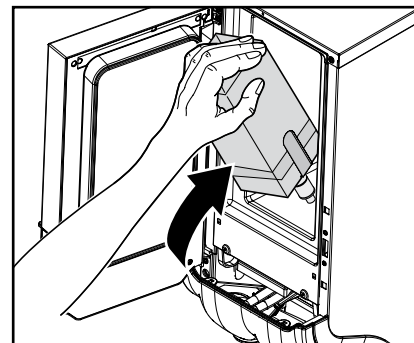

Fig. 20

### Replacing an empty product pack



**Caution:**

Before inserting a new product pack, follow the instructions in chapter „Food safety instructions (HACCP)“.

1. Wash your hands before touching a product pack.
2. Do not use a frozen product pack.



**Caution:**

Read the instructions on the product pack. Never use a damaged product pack. Do not use a product pack if the „Best before“ date has expired (fig. 18).

3. Shake the product pack at least 10 times (fig. 18).
4. Remove the plastic wrapper and write the „Expiry date“ on the product pack (fig. 19).
5. Follow the instructions on the product pack to open the doser (fig. 19).

6. Open the dispenser door.
7. Insert the product pack (fig. 20).
8. Close the dispenser door.
9. Dispense a test drink.

## Switching on the dispenser



**Caution:**

Ensure, that the dispenser is connected to the water supply.

1. Open the water tap.
2. Insert the power plug.

The dispenser starts heating up water and starts cooling down the cooling compartment. Drink delivery will be blocked until the water in the boiler has reached the correct temperature.

A flashing thermometer and the icon for „Delivery blocked“ will be shown on the display:



**Note:**

Depending on the dispenser model (see „Technical Specifications“) and the ambient temperature, the heating of the boiler can take between 30 and 120 minutes. The cooling of the product compartment can take 24 hours or more.

Once the water has reached the preset temperature, the display shows the animated symbol illustrated below. The dispenser is now ready for operation.



**Note:**

If the dispenser has been shut down for longer periods, the date and time must be set, so that the dispenser and the programmed cleaning cycles are reactivated, please see the descriptions on the following page.

## I 4 OPERATING THE DISPENSER

### Setting date and time

The date and time settings are shown on the display. The option «MONTH» is active and flashing:

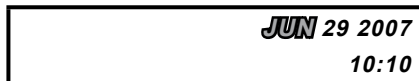

1. Press the buttons ,UP/'DOWN' ▼▲ to select the correct month (JAN - DEC).
2. Press the ,ENTER' button ◀ to confirm.

The option «MONTH» stays lit and the option «DAY» starts to flash:



3. Press the buttons ,UP/'DOWN' ▼▲ to select the correct day (1-31).
4. Press the ,ENTER' button ◀ to confirm.

The option «DAY» stays lit and the option «YEAR» starts to flash:

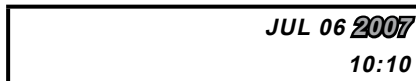

5. Press the buttons ,UP/'DOWN' ▼▲ to select the correct year.
6. Press the ,ENTER' button ◀ to confirm.

The option «YEAR» stays lit and the option «HOUR» starts to flash:

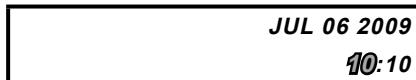

7. Press the buttons ,UP/'DOWN' ▼▲ to select the correct hour.
8. Press the ,ENTER' button ◀ to confirm.

The option «HOUR» stays lit and the option «MINUTES» starts to flash:

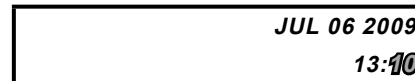

9. Press the buttons ,UP/'DOWN' ▼▲ to select the correct minutes.
10. Press the ,ENTER' button ◀ to confirm.

After a short time, the new settings for date and time will be displayed continuously (without flashing) on the display:



## Switching off the dispenser

1. Remove the product pack and check the „Expiry” date.
- Store the product pack in a refrigerator until you switch the dispenser back on again.
- When the expiry date has passed, throw the product pack away.



**Warning:**

**Do not freeze product packs.**

2. Clean and flush the dispenser.
3. Pull the power plug out of the socket.
4. Close the water tap.

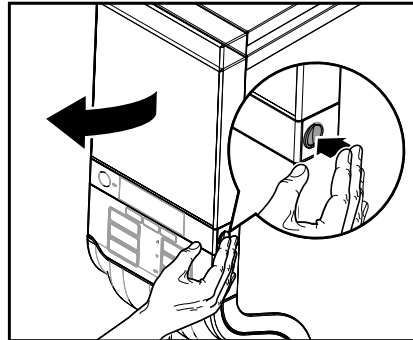

**Fig. 21**

## Locking/unlocking the dispenser

1. Open the dispenser door (fig. 21).
2. Press the **LOCK**/Clear-Error switch to block the drink delivery (fig. 22).

The lock icon appears on the display.



Drink delivery will be switched off. The cooling compartment and the boiler will remain in operation.



**Fig. 22**

3. To unlock the dispenser, press the **LOCK**/Clear-Error switch again to enable drink delivery (fig. 22).

## 5 CLEANING THE DISPENSER

### Cleaning procedures

It is recommended, that you clean your dispenser at regular intervals. There are two optional procedures:

- ‚Clean & Flush‘ the cooling compartment and the drink outlets.



#### Caution:

It is recommended to carry out the procedure „Clean & Flush“ once a week.

For the operation with choco product packs, the ‚Clean & Flush‘ procedure is required.

- ‚Flush‘ the drink outlets

### Clean & Flush

The dispenser has a built-in timer that will prompt you at least one day a week to ‚Clean & Flush‘.

The service technician can enable or disable the built-in-timer and set the weekday(s) for ‚Flush‘ and ‚Clean & Flush‘ according to your needs. (only for coffee and tea product packs).

### When is cleaning due?

- You must clean the dispenser when the display indicates that cleaning is required.

The cleaning icon appears in the display:



### When is cleaning overdue?

If the dispenser is not cleaned within 24 hours, the drink delivery will be blocked.

The display then shows an icon in the form of a crossed-out cup:



Start the cleaning program.

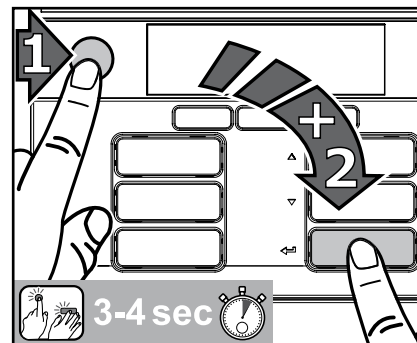

Fig. 23

### Start ‚Clean & Flush‘

1. Press first the STOP button and then the enter button ◀ and hold them pressed simultaneously for 3-4 seconds to enter the cleaning mode (fig. 23).

Follow the instructions on the display:

**PLEASE REMOVE PRODUCT PACK**

2. Open the dispenser door.
3. Remove the product pack.

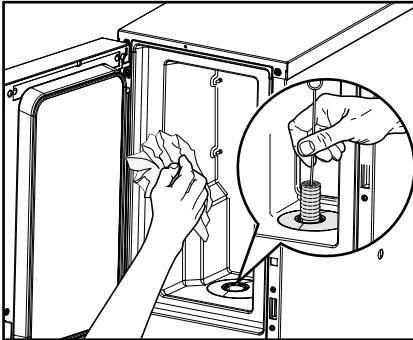

Fig. 24

The following message appears on the display:

**PLEASE CLEAN THE COOLING INTERIOR AND PUT BACK THE PRODUCT PACK.**

4. Clean the interior of the cooling compartment with a clean, damp cloth and the doser opening with a brush (fig. 24).
5. Insert the product pack.
6. Close the dispenser door.

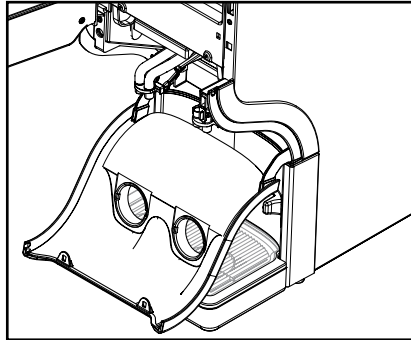

Fig. 25

The following message appears on the display:

**PLEASE REMOVE AND CLEAN THE MIXING BOWL OR USE EXCHANGE KIT.**

- Note:**  
 To reduce the cleaning time, we recommend the use of an exchange kit, which consists of a clean mixing bowl and sealing ring. Without this exchange kit, cleaning will take as long as is necessary to clean the mixing bowl.

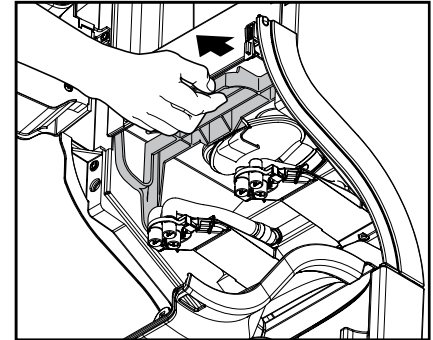

Fig. 26

7. Clean the mixing bowl:
  - a. Remove the cup tray if necessary.
  - b. Pull the outlet cover down (fig.25).
  - c. Pull the release bar to release the complete mixing console (fig. 26).

## I 5 CLEANING THE DISPENSER

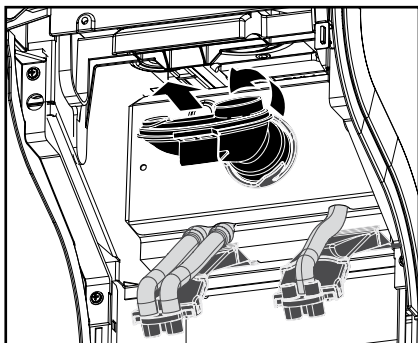

Fig. 27

- d. Rotate the mixing bowl counter-clockwise to release it and remove it with the sealing ring (fig. 27).

When the mixing bowl is removed from the dispenser, the following message appears on the display:

**PLEASE PLACE BACK A  
CLEAN MIXING BOWL AND  
CLOSE THE CONSOLE UNTIL  
YOU HEAR A BEEP.**

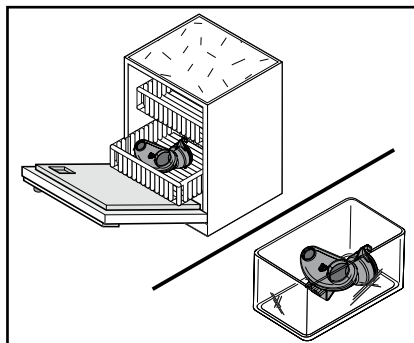

Fig. 28

- e. Clean the mixing bowl and the sealing ring (fig. 28):
- Either in a dishwasher, or
  - Soak it for 15 minutes in warm water with a cleaning agent, approved by the food industry.
- f. Rinse the mixing bowl and sealing ring with clear water and dry off with a clean paper cloth.



**Caution:**

Ensure that the sealing ring sits correctly in the groove of the mixing bowl.

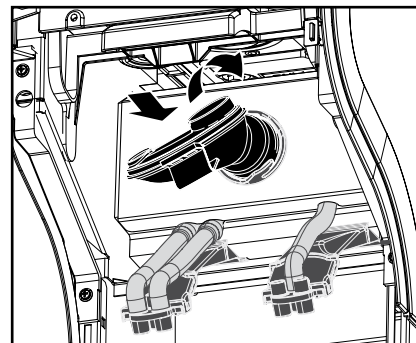

Fig. 29

- g. Insert the mixing bowl and sealing ring, then rotate it clockwise until it engages (fig. 29).
- h. Press the mixing console upwards until you hear a click.
- i. Pull the outlet cover upwards and fix it.
- k. Place the cup tray back.

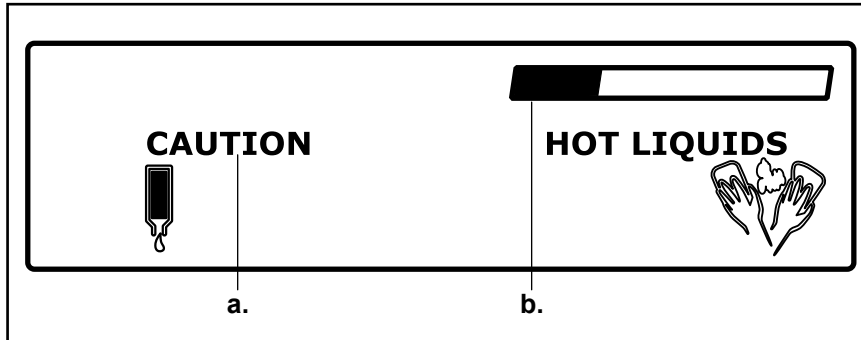

Fig. 30

The following message appears on the display:

**PLEASE PLACE FLUSH BIN  
(MIN. 4L.) AND PRESS ◀ FOR  
OK.**

8. Place the flush bin under both product outlets and press the enter button ◀.



**Warning:**

**The liquids dispensed by the dispenser are hot! Avoid scalding! Keep hands and other body parts away from the dispenser.**

The following message appears on the display:

**PRESS ◀ TO FLUSH**

9. Press the enter button ◀ to start the flushing process.

The flush process starts (fig. 30):

- a. CAUTION sign  
b. Shows the progress of flushing

After flushing is complete, the dispenser is ready for operation.

### Flush

According to your own needs, the service technician can optionally set weekdays for ‚Flush‘ in the built in timer.

In this case, the icon for cleaning appears on the display on the set weekday and you can then start flushing.

You can carry out the ‚Flush‘ procedure at any time you like.

### Start the ‚Flush‘ procedure

1. Press first the STOP button and then the enter button  and hold them pressed simultaneously for 3-4 seconds to enter the cleaning mode.

Follow the instructions on the display (see also page 24):

**PLEASE PLACE FLUSH BIN  
(MIN. 4L.) AND PRESS  FOR  
OK.**

2. Place the flush bin under both product outlets and press the enter button .



*Warning:*

**The liquids dispensed by the dispenser are hot! Avoid scalding! Keep hands and other body parts away from the dispenser.**

The following message appears on the display:

**PRESS  TO FLUSH**

3. Press the enter button  to start the flushing process.

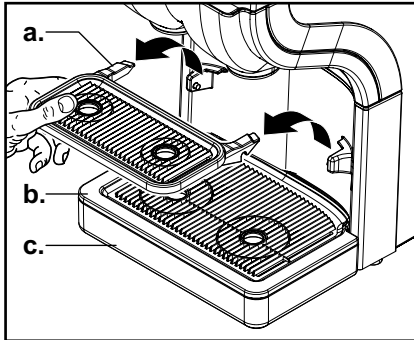

Fig. 31

### Manual daily cleaning of external parts

1. Open the dispenser door and press the **LOCK**/Clear-Error switch to set the dispenser to locked mode.

**Note:**  
This avoids to dispense drinks or hot water accidentally when cleaning the external parts.

2. Remove cup tray (a.), drip grid (b.) , and drip tray (c.), (fig. 31)

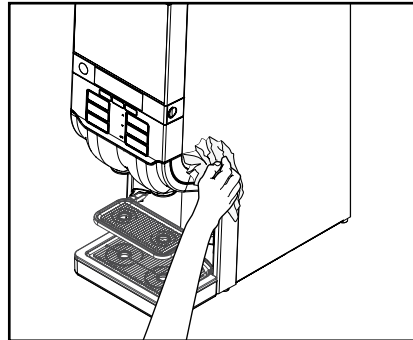

Fig. 32







3. Empty the drip tray.





**Note:**  
Check and empty the drip tray at regular intervals.

4. Clean the external parts with a damp, clean cloth and rinse off with clear water.
5. Put the cup tray, drip grid and drip tray back into place.
6. Wipe down the exterior of the dispenser with a damp and clean cloth (fig. 32).

- Note:**  
The parts can also be cleaned in a dishwasher.
- Note:**  
Comply with the safety instructions and cleaning instructions on the cleaning agent packaging.

## 6 DISPLAY MESSAGES AND TROUBLE SHOOTING

Display messages	Cause	Action
 0123456789 	<p>The product pack is:</p> <ul style="list-style-type: none"> <li>• empty</li> <li>• incorrectly positioned</li> <li>• or not present</li> </ul>	<p>Call the operator when the number is shown on the display.</p> <ul style="list-style-type: none"> <li>• Replace the empty product pack, see page 17.</li> <li>• Check whether the product pack is inserted correctly, see page 17.</li> <li>• Insert a product pack</li> </ul>
	<p>The drink delivery is blocked because the dispenser was not cleaned as scheduled.</p>	<p>Start the cleaning program immediately, see page 21.</p>
  <b>PLEASE WAIT BOILER IS HEATING UP</b>	<p>The water in the boiler has not yet reached the preset temperature.</p>	<p>The drink delivery of the dispenser is blocked until the temperature reaches the correct value.</p>
 	<p>The drink delivery is blocked because the <b>LOCK</b>/Clear-Error switch on the dispenser was pressed.</p>	<ul style="list-style-type: none"> <li>• Press the <b>LOCK</b>/Clear-Error switch again to unlock the dispenser, see page 20.</li> </ul>

Display messages	Cause	Action
 0123456789 	The dispenser must be cleaned.	<ul style="list-style-type: none"> <li>• Call the operator when the number is shown on the display.</li> <li>• Start the cleaning program on the same day, see page 21.</li> </ul>
 <b>ECO</b>	The drink delivery is blocked because the energy saving mode of the dispenser is switched on.	<ul style="list-style-type: none"> <li>• Press a drink button. The boiler temperature increases and the drink is dispensed as soon as the correct temperature is reached. The energy saving mode becomes active again 10 minutes after the boiler was heated up or the last drink was dispensed.</li> </ul>
	The water filter of the dispenser must be replaced.	Replace the water filter.
 0123456789 <i>Err 19</i>	Error water system:	<p>Check the water supply line to the dispenser is blocked, open the water tap completely.</p> <p>Press the <b>LOCK</b>/Clear-Error switch.</p> <p>Contact service, if the error remains.</p>

## I 6 DISPLAY MESSAGES AND TROUBLE SHOOTING

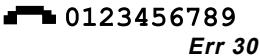
Display messages	Cause	Action
 <p>0123456789 <i>Err 30</i></p>	<p>Errors cooling:</p>	<p>Check the ventilation and the ambient temperature of the dispenser, and clean the ventilation grid, if necessary.</p> <p>Press the <b>LOCK</b>/Clear-Error switch.</p> <p>Contact service, if the error remains.</p>
<p>Water leaks from the hot water outlet or a product outlet.</p>	<p>Scale particles block the respective outlet valve, it cannot close completely.</p>	<p>Perform the program ‚Flushing‘.</p> <p>Contact service if the problem persists.</p>
<p>The dispenser does not respond to pressing a button or touch screen input.</p>	<p>A software jam has occurred.</p>	<p>Reset the dispenser:</p> <p>Disconnect the power supply and connect again after 5 seconds.</p> <p>Contact service if the problem persists.</p>

## 7 TECHNICAL SPECIFICATION

Technical Specifications	Cafitesse 120
Dispenser versions	Standard version hot drinks - cup & pot delivery Café Cool version hot and cold drinks - cup & pot delivery
Dimensions	
Height	850 mm / 33.5 in.
Width	260 mm / 10.2 in.
Depth	522 mm / 20.6 in.
Weight	
empty	34.0 kg / 75.0 lbs
filled	45.0 kg / 99.2 lbs
Maximum cup/pot height	Cups: 117 mm (4.6 in) using the cup tray Pots: 210 mm (8.3 in) with cup tray folded Pots: 260 mm (10.2 in) without drip tray Air pots: 33 cm (13.4 in.) when using the optional air pot extension. („Options“)
Ingredient capacity	1 disposable Bag-in-Box (BIB) ingredient packs with a capacity of: 2 litre/0.53 gal, or 1.25 litre/0.33 gal. (Use the small optional adapters for ingredient packs („Options“))
Drink capacity	100 cups at 100 cc (3.3 fl. oz. USA) per hour per kW heating capacity
Standard water connection	1/2" or 3/8" supply line with 3/4" BSP connecting piece Drinking water line with stop valve Max. water inlet temperature 60 °C/140 °F

## I 7 TECHNICAL SPECIFICATION

### Technical Specifications

### Cafitesse 120

---

Dynamic pressure	Min. 0.8 bar at 10 l/min - 11 psi at 2.6 USgal/min
Static pressure	Max. 10 bar - 140 psi
Boiler capacity	9 litre/2.4 USgal
Hot water connection	Via copper pipes only
Connection water cooling unit:	Dynamic pressure: min. 0.8 bar at 1.2 l/min - 11 psi at 0.7 USgal/min
Refrigerant	0.035 kg of R134a
Electrical specification:	<ul style="list-style-type: none"><li>• By power cord and plug 1.80 m (70.9 in)</li><li>• Direct power connection according to the Safety Instructions</li></ul> <p>For the connected loads refer to the rating plate.</p> 1-phase operation USA: max. 1.8 kW at AC 120V 1-phase operation (120/240 V) USA: <ul style="list-style-type: none"><li>• max. 9.3 kW at AC 120/240 V</li><li>• max. 5.8 kW at AC 120/240 V</li><li>• max. 3.9 kW at AC 120/240 V</li></ul>
Environmental specifications	
Acoustic Emission	The A-weighted sound pressure level of the dispenser is below 70 dB.
Ambient Temperature for installation & operation	Between 5 °C/41 °F and 32 °C/90 °F.
Compliance	UL/cUL, NSF label

The manufacturer reserves the right to change specifications without prior notice.

## 8 OPTIONS

The features and options listed in this section may not apply in each country. Please consult your Cafitesse system supplier for more information.

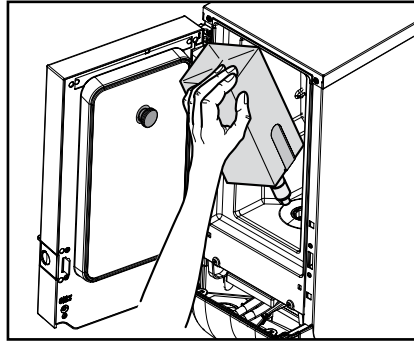
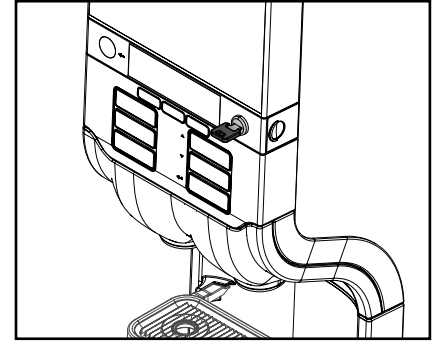

*Fig. 33*

### Hardware accessories

#### Adapters for small ingredient packs

To use the dispenser with 1.25 litre/0.33 gal ingredient packs, your Cafitesse system supplier can provide special magnetic adapters for the ingredient storage to secure the packs into their position. (Fig. 33)



*Fig. 34*

#### Door lock

On your request, the service technician can install a mechanical door lock in the dispenser door. In this way an unauthorized access to the dispenser can be prevented. (Fig. 34)

### Software options

On customer demand the service technician can enable or disable specific functions of your dispenser. For example:

- Alternative settings for drink recipes, varieties, strength or cup volume.
- Enable/disable preset selections such as drink strength (mild, normal, strong) or cup size (small, medium, large).
- Portioned or continuous delivery.
- Custom energy saving settings.
- Custom cleaning settings according to your preference.

## I 8 OPTIONS

### **Air pot Extension**

To allow the use of large pots like air pots, the service technician can install a special dispenser foot to increase the delivery height of the dispenser outlets to 33 cm (13.4 in.).

### **Cocoa containing drinks**

If you would like to offer cocoa containing drinks, the service technician can equip your dispenser with a special mixing unit.

### **Water cooling unit**

For the additional delivery of cold water and cold drinks, the service technician can equip your dispenser with a special water cooling unit.



**Caution:**

Test the quality of the water supply to ensure delivery of safe cold drinks according to local regulations.

## 9 INDEX

### A

Ambient temperature, 19, 30

### B

‚Best before‘ date, 8, 10, 18

### C

Cleaning, 10, 12, 22-27,

Cleaning procedures, 22, 26

Cleaning settings, 22, 33

Continuous delivery, 14

Cooling compartment, 11, 12, 19-23

Cooling system, 19

Cup tray, 11, 13, 15, 16, 27

### D

Daily cleaning, 27

Decalc, 12

Display, 11, 12

Drink delivery, 13-15

Drink strength, 16

Drink button, 11, 13

Drip grid, drip tray, 11

### E

ECO, 12, 29

Energy saving mode, 12

Error, 11

‚Expiry‘ date, 9, 10, 18, 19

Exchange kit, 23

### F

Filter (water filter), 12

First in - First out principle, 8

Flushing, 25, 26

Front of the dispenser, 6, 12

Food safety, 4, 8, 10, 18, 22

### H

HACCP, 8, 10, 18

Hot water, 4

### I

ICED preselection, 12, 15, 17

Installation, 6

### L

**LOCK**/Clear-Error switch, 11, 20, 27,

### M

Manual daily cleaning, 27

Mixing bowl, 23, 24

Mixing console, 23, 24

### O

Outlet cover, 23, 24

Operation, 4, 5, 7, 8

### P

Power cord, 6, 11,

Power supply, 19

Portioned delivery, 14

Portion size, 15

Preselection, 11, 12, 15, 16

Product pack, 4, 7-9, 12, 17-19

### R

Rear of the dispenser, 6, 12

Refrigerator, 7, 19

### S

Safety instructions, 4, 5, 8, 10, 18, 27

Sealing ring, 24

Service mode, 12

Storage, 7, 8

Strength preselection, 15, 16

Switching on, 19

Switching off, 19

### T

Technical specifications, 31, 32

Telephone number, 17

Transport, 7, 8

Training, 10

### V

Volume preselection, 12, 15

### W

Water supply, 6, 11, 19

Weight, 31, 32

**CLEANING (weekly)**

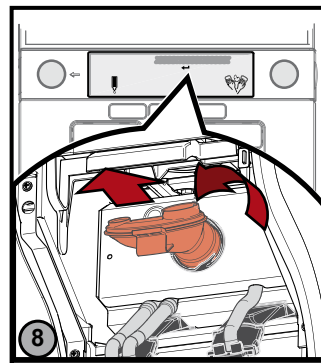
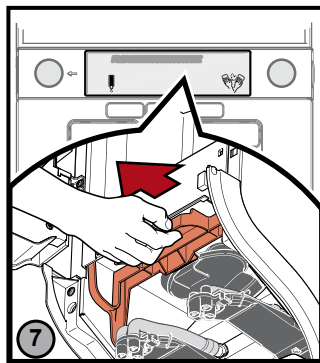
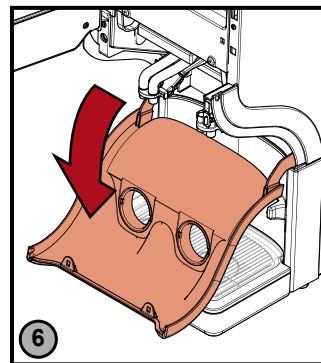
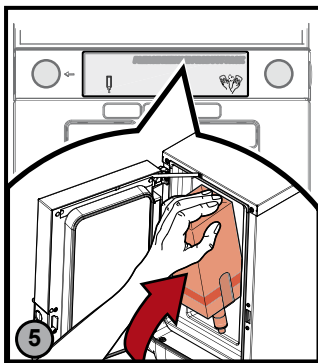
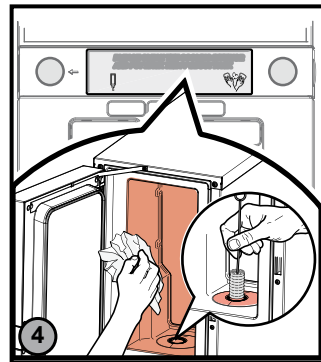
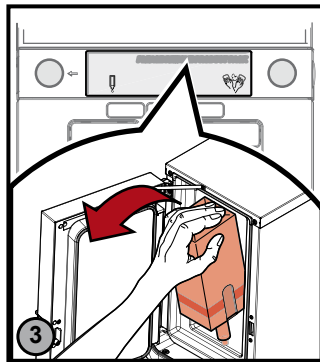
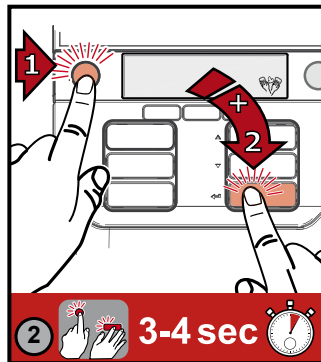
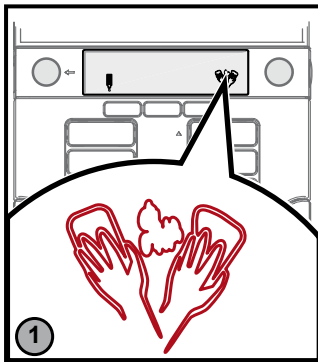

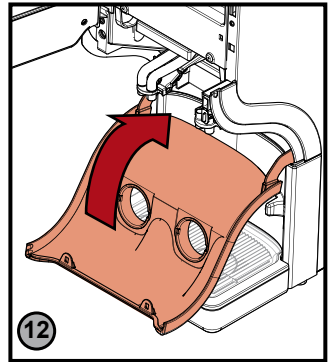
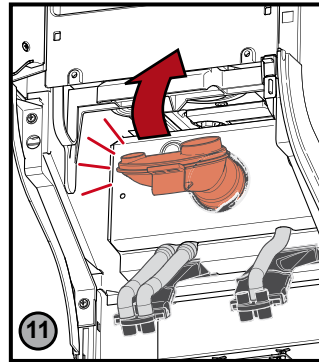
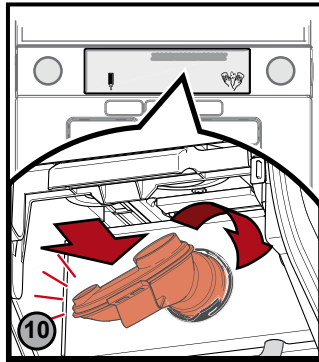
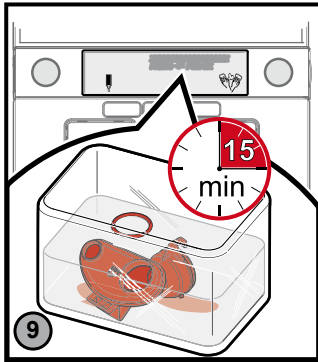

*optional*

**FLUSHING**

